

SPECIFICATION

OF

LIQUID CRYSTAL DISPLAY MODULE



CUSTOMER : U.R.T. STANDARD

Model No. : UMSH-7763MD-B

Model version : 1

Document Revision : 6

CUSTOMER APPROVED SIGNATURE			

This specification need to be signed by purchaser or customer as a specification of products production and delivery from URT. Without signature of this specification , any purchase order for this model no. will be treated and considered that this specification is automatically acknowledged and accepted by purchaser or customer.

 **U.R.T.**  **UNITED RADIANT TECHNOLOGY CORPORATION**

Allen Wang
APPROVED

George Tseng
CHECKED

Angus Chiu
CHECKED

Sharon Tsai
PREPARED

Jan-8-2009
Date

COMPANY : No. 2,Fu-hsing Road,Taichung Economic Processing Zone,Tantzu,Taichung,Taiwan,R.O.C.
TEL: 886-4-25314277 FAX: 886-4-25313067



Revision 6 ; UMSH-7763MD-B Ver. 1 ; January-08-2009

Page: 1

Revision record

Document Revision	Model No. Version No.	Description	Revision by
0	UMSH-7763JD-F (USSH-E749J-1F) Version No. 0		Kim Lin Gary Yang 16-Feb-2006
1	UMSH-7763JD-1F (USSH-E749J-1F) Version No. 0	1. Increased U.R.T. standard touch panel. 2. Modify the module number from UMSH-7763JD-F to UMSH-7763JD-1F.	T.J. Yang Gary Yang 10-Jan-2007
2	UMSH-7763JD-2F (USSH-E749J-1F) Version No. 0	1. Modify the driver IC version . 2. Modify the lifetime of the Led chip from 10000 hrs to 50000 hrs. 3. Modify the module number from UMSH-7763JD-F to UMSH-7763JD-2F.	Flyon Liao Gary Yang 21-May-2007
3	UMSH-7763JD-3F (USSH-M008JY-F) Version No. 0	1. Modify the L type of PCB 2. Modify the module number from UMSH-7763JD-2F to UMSH-7763JD-3F.	Flyon Liao Albert Lin 09-Nov-2007
4	UMSH-7763JD-4F (USSH-M008JY-F) Version No. 0	1. Add the touch panel. 2. Modify the module number from UMSH-7763JD-3F to UMSH-7763JD-4F.	Flyon Liao Albert Lin 07-Dec-2007
5	UMSH-7763MD-B (USSH-M008ENY-B) Version No. 0	1. Modify the display mode and LCD type. 2. Modify the module number from UMSH-7763JD-3F to UMSH-7763MD-B.	Flyon Liao Chih Hao Huang 29-Dec-2008
6	UMSH-7763MD-B (USSH-M008ENY-B) Version No. 1	1. Modify the words of LCD Type from 5.7" FSTN to 5.7" STN.	Flyon Liao Chih Hao Huang 08-Jan-2009
			Revision 6 ; UMSH-7763MD-B Ver. 1 ; January-08-2009
			Page: 2

CONTENTS:

No.	Item	Page
1	BASIC SPECIFICATION	
	1.1 Mechanical Specification	4
	1.2 Display Specification	4
	1.3 Outline Dimension	5
	1.4 Block Diagram	6
	1.5 Interface Pin	7
2	ELECTRICAL CHARACTERISTICS	
	2.1 Absolute Maximum Ratings	8
	2.2 DC Characteristics	9
	2.2.1 Backlight Specification	10
	2.3 AC Characteristics	11~12
	2.4 Operation Timing	13~14
3	OPTICAL CHARACTERISTICS	
	3.1 Characteristics	15
	3.2 Definition of Optical Characteristics	16
4	RELIABILITY	17
5	PRODUCT HANDING AND APPLICATION	18
6	DATECODE	19
7	PACKING & LOTNO	20~21
8	INSPECTION STANDARD	22~25

1. BASIC SPECIFICATION

1.1 Mechanical specifications

Items	Nominal Dimension	Unit
Dot Matrix	320 x 240 dots	dots
Module Size (W x H x T)	154.6 x 114.8 x 8.5	mm.
Viewing Area (W x H)	121.4 x 92.62	mm.
Active Area (W x H)	115.19 x 86.39	mm.
Dot Size (W x H)	0.33 x 0.33	mm.
Dot Pitch (W x H)	0.36 x 0.36	mm.
Driving method	1/240	Duty
	1/13	Bias
Driving IC Package	TAB	-
Module Weight	198	g

* Expose the driver IC under blaze
(luminosity over than 1 cd) when using the LCM may cause IC operating failure.

1.2 Display specification

Display	Descriptions	Note
LCD Type	5.7" STN	
LCD Mode	Negative	
Polarizer Mode	Transmissive	
Polarizer UV-Cutting	With	
Polarizer Surface	Normal	
Background Color	Blue	
Backlight Type	LED	
Backlight Color	White	
Viewing Angle	6 O'clock Direction	

1.3 Outline dimension

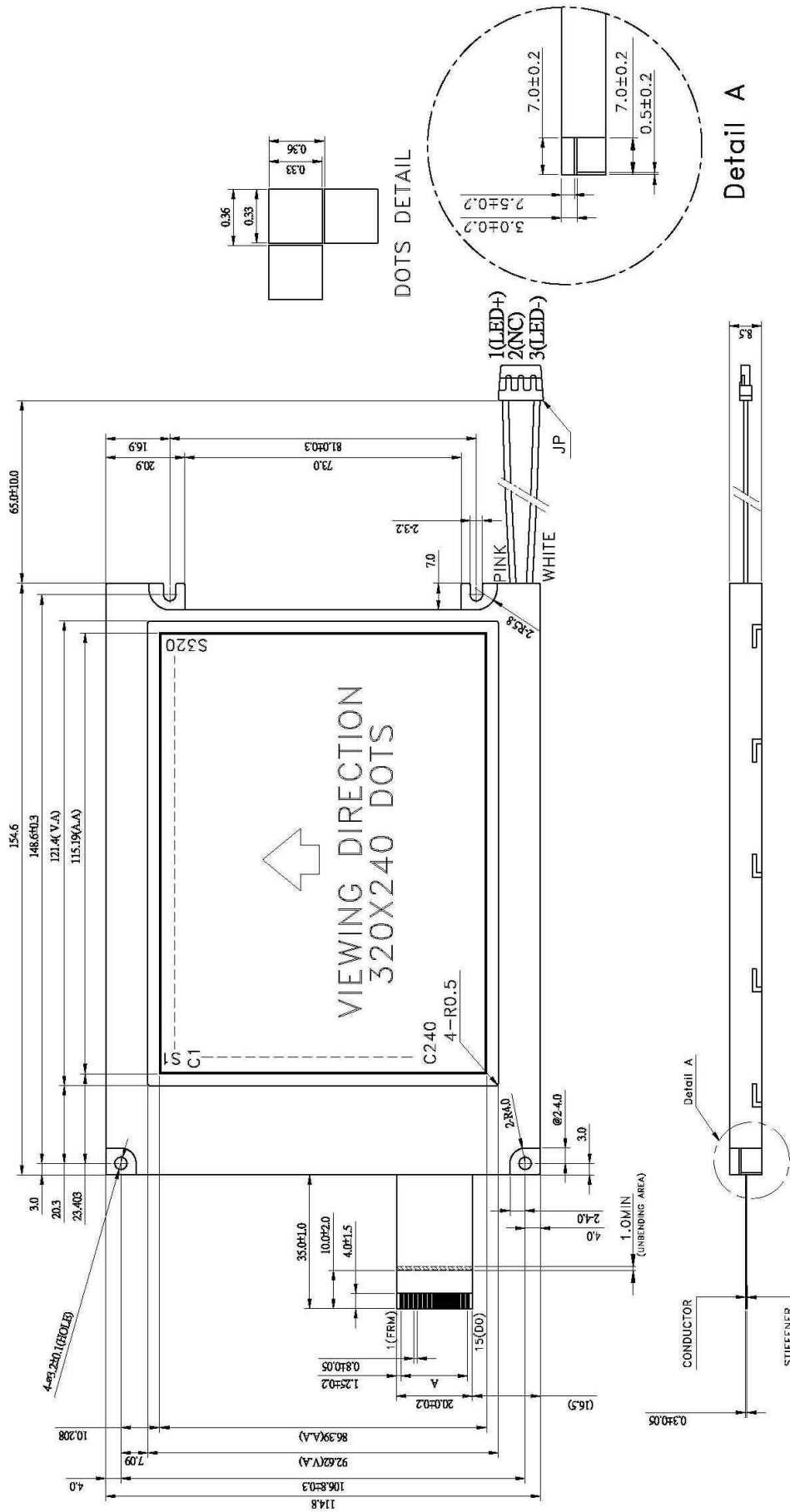

- NOTE:
- 1.LCD: BLUE STN TYPE, TRANSMISSIVE, NEGATIVE
 - 2.Top: -20°~+70°C; Tst: -20°~+70°C
 - 3.VIEWING DIRECTION: 6 O'CLOCK
 - 4.IC: NT7705H-TAB0009A + NT7701H-TABF1B
 - 5.JP: CONNECTOR HJST03
 - 6.A: 17.5±0.05(P1.25X14)
 - 7.LED COLOR: WHITE, 10 PCS
 - 8.CONSTANT VOLTAGE: 7.2V, IF:100mA±25mA
 - 9.RoHS COMPLIANT
 - 10.TOLERANCE FOR NOT ASSIGNED: ±0.5mm

1.4 Block diagram:

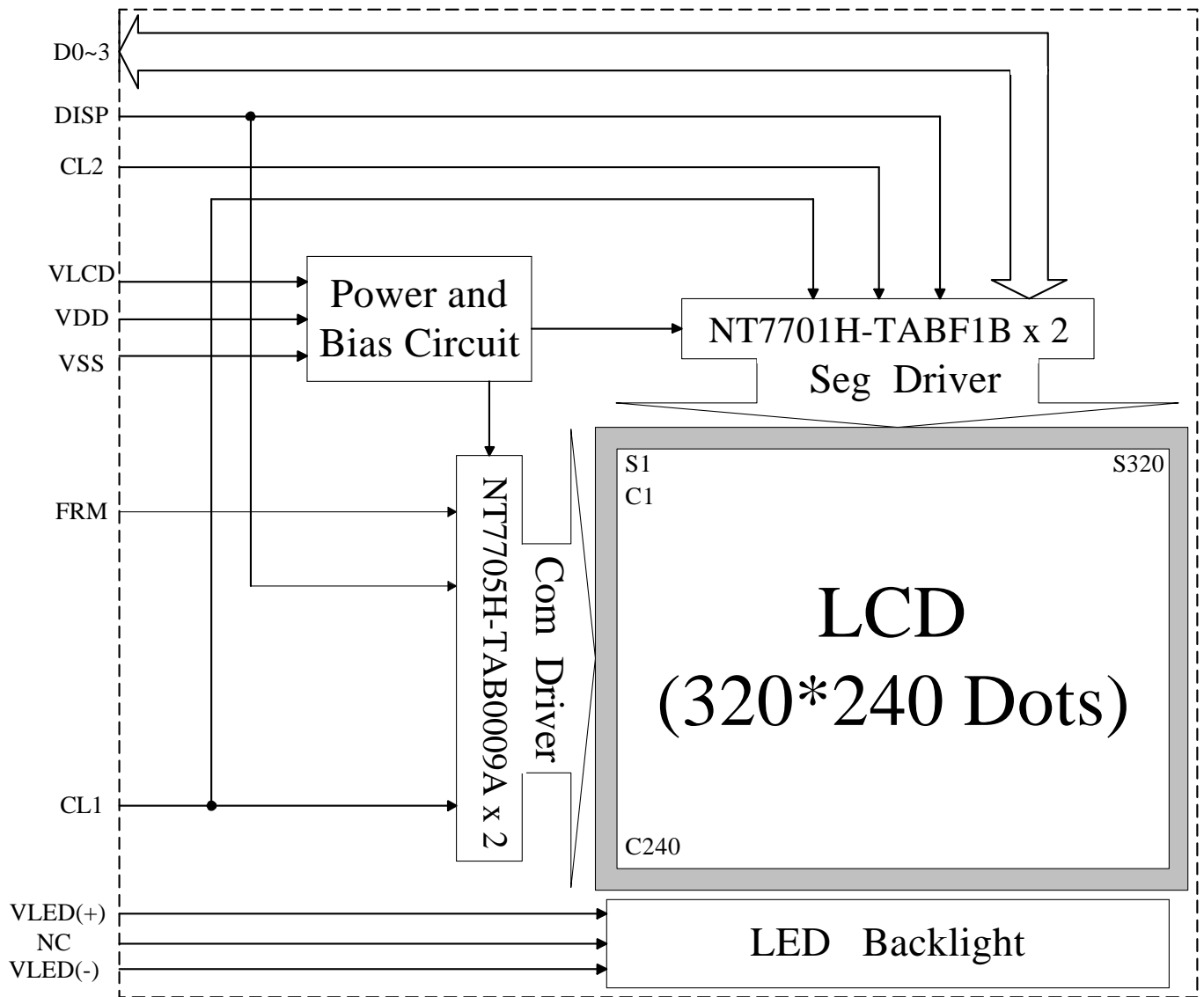

Example of Power Supply for LCM :

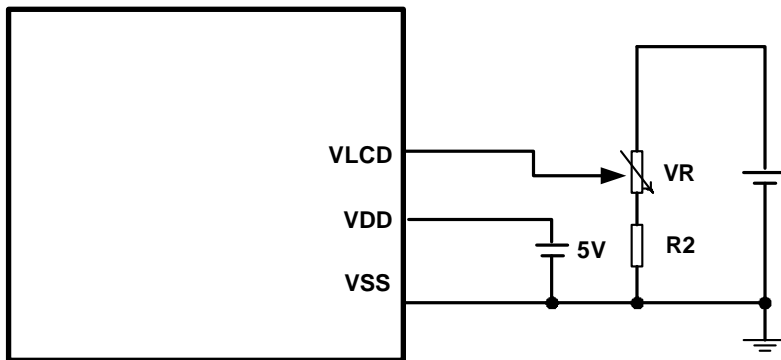

1.5 Interface pin :

Pin No.	Pin Symbol	I/O	Description
1	FRM	I	Start signal of frame.
2	CL1	I	Latch strobe signal.
3	CL2	I	Shift clock signal.
4	DISP	I	Display control signal. DISP="H":ON "L":OFF
5	VDD	P	Power supply voltage (+5.0V)
6	VSS	P	Ground (0V)
7	VLCD	P	Power supply for LCD driver.
8~11	NC	-	Dummy terminal.
12~15	D[3:0]	I	Bi-directional data bus.

Backlight interface pin :

Pin No.	Pin Symbol	I/O	Description
1	V _{LED(+)}	P	Anode of the LED Backlight.
2	NC	-	Dummy terminal.
3	V _{LED(-)}	P	Cathode of the LED Backlight (0V).

2. ELECTRICAL CHARACTERISTICS

2.1 Absolute Maximum Ratings

Items	Symbol	Min.	Max.	Unit
Supply voltage	VDD	-0.3	7.0	v
Supply voltage for LCD	VLCD	-0.3	+30	v
Input voltage	V _{IN}	-0.3	VDD+0.3	v
Operating temperature range	T _{OP}	-20	+70	°C
Storage temperature range	T _{ST}	-20	+70	°C

2.2 DC Characteristics

Items	Symbol	Min.	Typ.	Max.	Unit	Condition
Supply voltage (Logic)	VDD	2.5	5.0	5.5	V	-
Supply voltage (LCD)	VLCD	-	(19.9)	-	V	Top = 60°C
		21.0	22.0	23.0	V	NOTE1
		-	(22.4)	-	V	Top = -10°C
Frame frequency	FRM	-	75	-	Hz	-
Input high level voltage	V _{IH}	0.8VDD	-	-	V	-
Input low level voltage	V _{IL}	-	-	0.2VDD	V	-
Output high level voltage	V _{OH}	VDD-0.4	-	-	V	-
Output low level voltage	V _{OL}	-	-	+0.4	V	-
Power supply current(V _{DD})	I _{DD}	-	3.10	6.20	mA	NOTE2
Power supply current(V _{LCD})	I _{LCD}	-	6.92	13.84	mA	NOTE2

NOTE1 : Min. and Max. Voltage is mean within the range will has optimum contrast at Ta:25°C

Typ. Voltage is specified as module driving condition: Ta=25°C, V_{OP} at Optimum Contrast, the measuring condition as below, this value is URT recommend when customer change the set condition , the V_{LCD} will be change.

NOTE2 :

Measuring Condition :

Standard Value MAX.

Ta = 25°C

V_{DD}-V_{SS} = +5.0V

V_{LCD}-V_{SS} = V_{OP} at optimum Contrast

Bias = 1/13

Duty = 1/240

Display Patten = Checkered pattern

2.2.1 Back-light Specification :

PARAMETER	SYMBOL	MIN	TYP	MAX	Unit	Test Condition	NOTE
Supply Current	If	75	100	125	mA	Ta=25°C	-
Supply Voltage	Vs	-	7.2	-	V	Ta=25°C	-
Brightness	Br	1000	1200	-	cd/m ²	Ta=25°C If=100mA	-
Half-Life Time	Lf	-	50000	-	hrs	If=100mA	3

Note 3 : The “ Half-Life Time ”is defined as the LED chip brightness decrease to 50% original brightness , Base on Ta=25±2°C , 60±10%RH condition.

Measure Method

Definition of the 9 points(from 1 to 9) on Panel, refer to the figure as below.

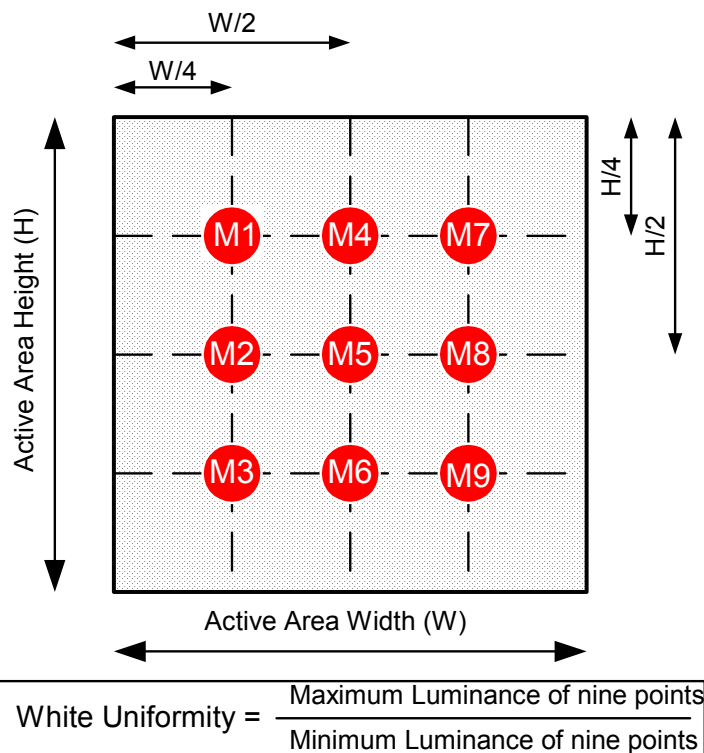

2.3 AC Characteristics

NT7701 (SEGMENT)

Segment Mode 1 ($V_{SS} = V_5 = 0V$, $V_{DD} = 4.5 - 5.5V$, $V_0 = 15$ to 30 , and $T_A = -30$ to $+85^\circ C$, unless otherwise noted)

Parameter	Symbol	Min.	Typ.	Max.	Unit	Condition
Shift clock period	twck	71	-		ns	tr, tf \leq 10ns, Note 1
Shift clock "H" pulse width	twckH	23	-		ns	
Shift clock "L" pulse width	twckL	23	-		ns	
Data setup time	tDS	10	-		ns	
Data hold time	tDH	20	-		ns	
Latch pulse "H" pulse width	twLPH	23	-		ns	
Shift clock rise to Latch pulse rise time	tLD	0	-		ns	
Shift clock fall to Latch pulse fall time	tSL	25	-		ns	
Latch pulse rise to Shift clock rise time	tLS	25	-		ns	
Latch pulse fall to Shift clock rise time	tLH	25	-		ns	
Input signal rise time	tr		-	50	ns	Note 2
Input signal fall time	tf		-	50	ns	Note 2
Enable setup time	ts	21	-		ns	
$\overline{\text{DISPOFF}}$ Removal time	tSD	100	-		ns	
$\overline{\text{DISPOFF}}$ enable pulse width	twDL	1.2	-		μs	
Output delay time (1)	td		-	40	ns	CL = 15pF
Output delay time (2)	t _{pd1} , t _{pd2}		-	1.2	μs	CL = 15pF
Output delay time (3)	t _{pd3}		-	1.2	μs	CL = 15pF

Note

1. Take the cascade connection into consideration.
2. $(T_{ck} - twckH - twckL)/2$ is the maximum in the case of high speed operation.

NT7705 (COMMON)

Common Mode ($V_{SS} = V_5 = 0V$, $V_{DD} = 2.5 - 5.5V$, $V_0 = 15$ to $40V$ and $T_A = -30$ to $+85^\circ C$, unless otherwise noted)

Parameter	Symbol	Min.	Typ.	Max.	Unit	Condition
Shift clock period	tWLP	250	-	-	ns	$t_r, t_f \leq 20ns$
Shift clock "H" pulse width	tWLPH	15	-	-	ns	$V_{DD} = +5.0V \pm 10\%$
		30	-	-	ns	$V_{DD} = +2.5 - +4.5V$
Data setup time	tSU	30	-	-	ns	
Data hole time	tH	50	-	-	ns	
Input signal rise time	t _r		-	50	ns	
Input signal fall time	t _f		-	50	ns	
$\overline{DISPOFF}$ Removal time	tSD	100	-	-	ns	
$\overline{DISPOFF}$ enable pulse width	tWDL	1.2	-	-	μs	
Output delay time (1)	tDL	-	-	200	ns	$C_L = 15pF$
Output delay time (2)	t _{pd1} , t _{pd2}	-	-	1.2	μs	$C_L = 15pF$
Output delay time (3)	t _{pd3}	-	-	1.2	μs	$C_L = 15pF$

2.4 Operation Timing

Timing waveform of the Segment Mode

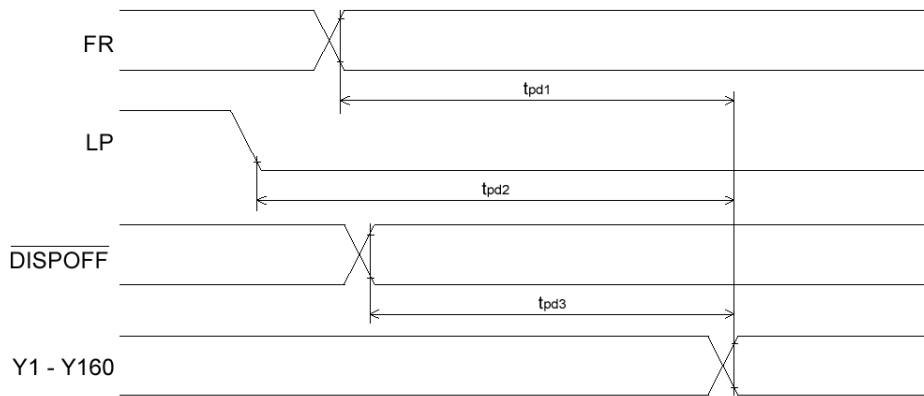
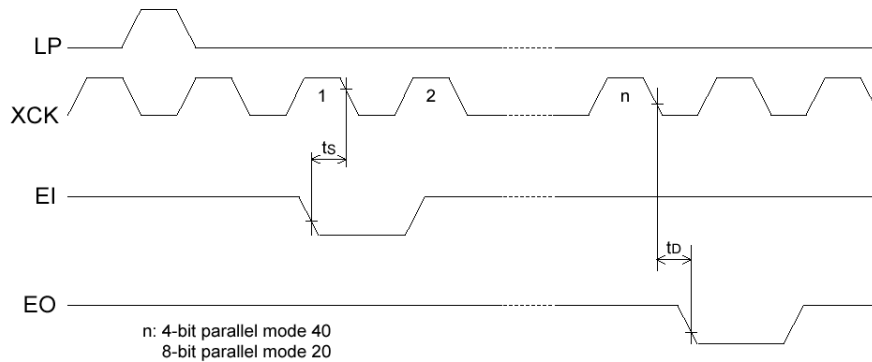
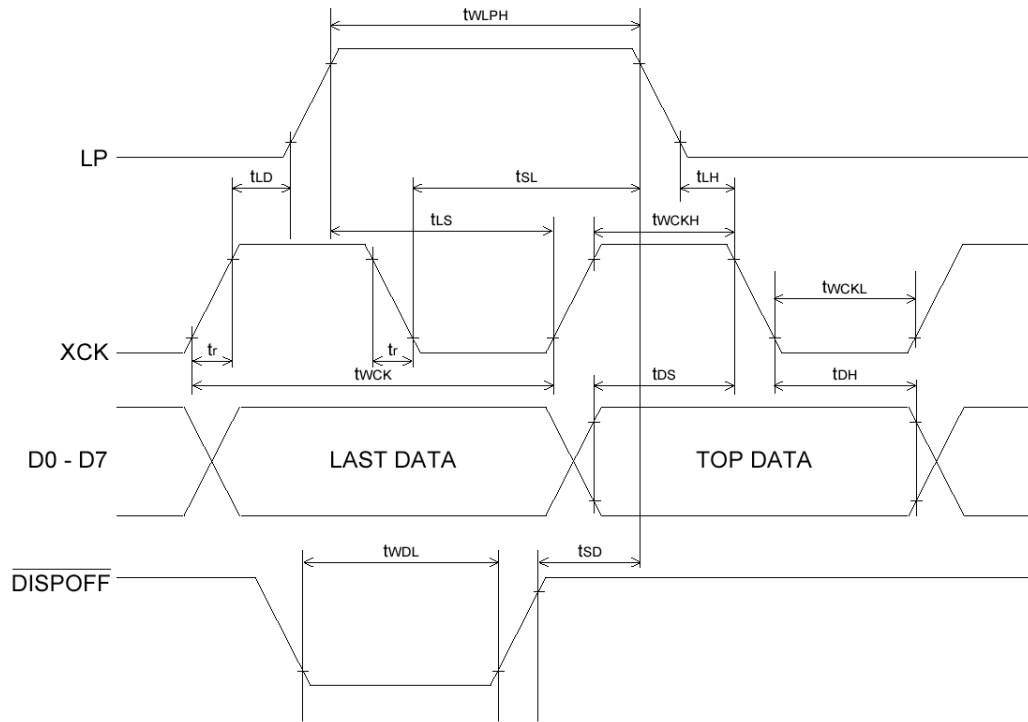

Timing Characteristics of Common Mode

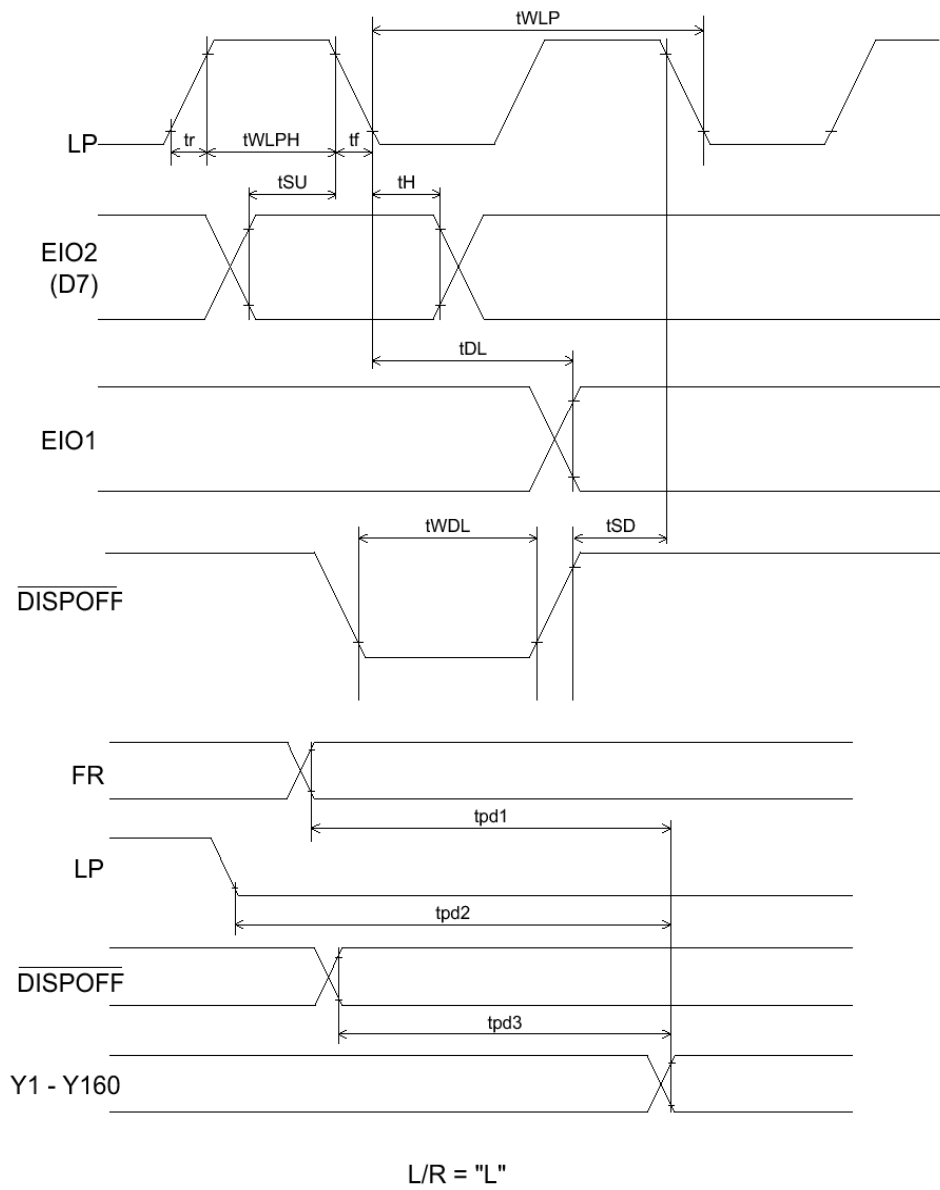

3. OPTICAL CHARACTERISTICS

3.1 Characteristics

Driving condition

Item	Duty	Bias	Note
Value	1/240	1/13	1

Electrical and Optical Characteristics

No.	Item	symbol / temp.		Min.	Typ.	Max.	Unit	Note	
1	Response Time	Tr	25	-	105	210	ms	2	
		Tf	25	-	290	580			
2	Viewing Angle	Front-Rear	1	=	-15	-	25	degree	3
		Left-Right	2	270°	-30	-	30		
3	Contrast Ratio	Cr	25	-	3	-	-	4	
4	White x-code	Wx		0.27	0.32	0.37		5	
	White y-code	Wy		0.29	0.34	0.39			
	Brightness	Y		150	250	-			cd/m ²
5	Brightness Uniformity		25	70	-	-	%	6	

3.2 Definition of optical characteristics

Measurement condition :

Transmissive and Transflective type

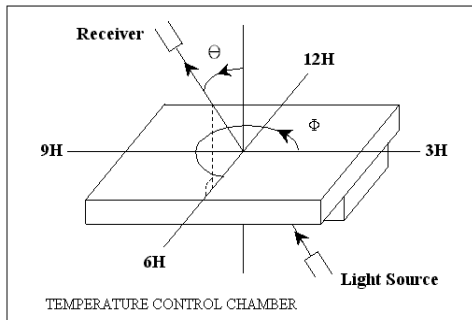

PHOTAL LCD-5000

[Note 1] Definition of LCD Driving Vop and Waveform :

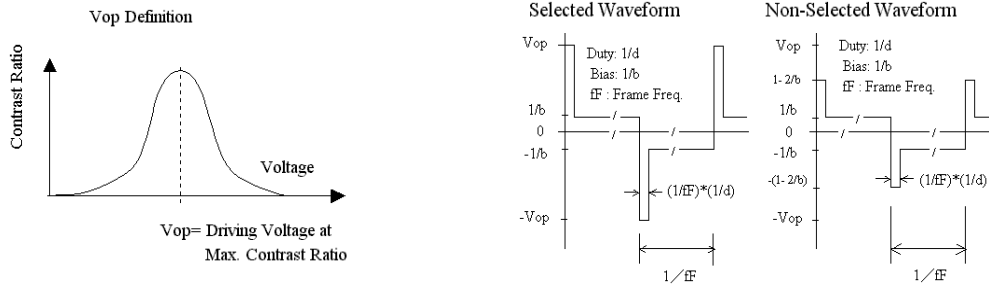

[Note 2] Definition of Response Time

for Negative type :

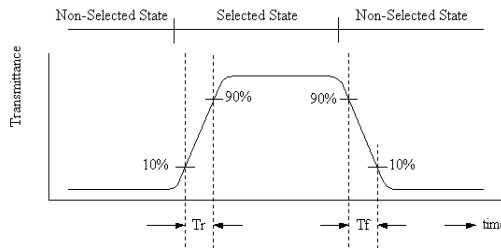

[Note 3] Definition of Viewing Angle :

[Note 4] Definition of Contrast Ratio :

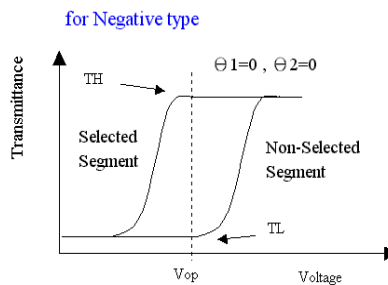
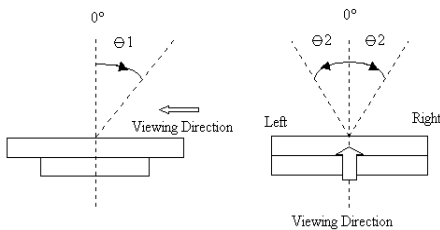

$$\text{Contrast Ratio} = \frac{TH}{TL}$$

4. RELIABILITY :

Item No	Items	Condition
1	High temperature operating	70 , 200 hours
2	Low temperature operating	-20 , 200 hours
3	High temperature storage	60 , 200 hours
4	Low temperature storage	-10 , 200 hours
5	High temperature & humidity storage	60 , 90%RH, 100 hours
6	Thermal Shock storage	-10 , 30min.<=> 60 , 30min. 10 Cycles
7	Vibration test	10 => 55 =>10 => 55 => 10 Hz , within 1 minute Amplitude : 1.5mm. 15 minutes for each Direction (X,Y,Z)
8	Drop test	Packed, 100CM free fall, 6 sides, 1 corner, 3edges
9	Life time	50,000 hours 25 , 70%RH below , specification condition driving

- * One single product test for only one item.
- * Judgment after test : keep in room temperature for more than 2 hours.
 - Current consumption < 2 times of initial value
 - Contrast > 1/2 initial value
 - Function : work normally

5. PRODUCT HANDLING AND APPLICATION

PRECAUTION FOR HANDLING LCM

The LCD module contains a C-MOS LSI. People who operate the LCM should wear ESD protection equipment to prevent ESD hurt on products.

Do not input any signal before power is turned on.

Do not take LCM from its packaging bag until it is assembled.

Peel off the LCM protective film slowly since static electricity may be generated.

Pay attention to the humidity of the work shop, 50~60%RH is satisfactory.

Use a non-leak iron for soldering LCM.

Do not touch the display surface or connection terminals area with bare hands. Smudges on the display surface reduce the insulation between terminals.

Cautions for soldering to LCM:

Condition for soldering I/O terminals:

Temperature at iron tip : 280 ±10 .

Soldering time : 3~4sec./ terminals.

Type of solder : Eutectic solder(rosin flux filled).

PRECAUTION IN USE OF LCD

Do not contact or scratch the front surface and the contact pads of a LCD panel with hard materials such as metal or glass or with one's nail.

To clean the surface , wipe it gently with soft cloth dampened by alcohol.

Do not attempt to wipe off the contact pads.

Keep LCD panels away from direct sunlight , also avoid them in high-temperature & high humidity environment for a long period.

Do not drive LCD panels by DC voltage.

Do not expose LCD panels to organic solvent.

Liquid in LCD is hazardous substance. In case a contact with liquid crystal material is occurred, be sure to immediately wash such material away by soap and water.

The polarizer is easily damaged and should be handle with special care. Don't press or rub it with hard objects.

PRECAUTION FOR STORING LCM

To avoid degradation of the device , do not store the module under the conditions of direct sunlight , high temperature or high humidity . Keep the module in bags designed to prevent static electricity charging under low temperature / normal humidity conditions(avoid high temperature / high humidity and low temperature below 0)

USING ON MEDICAL CARE , SAFETY OR HAZARDOUS APPLICATION OR SYSTEM

For the application in medical care, safety and hazardous products or systems, an authorization from URT is required. URT will not responsible for any damage or loss which caused by the products without any authorization given by URT.

This product is not allowed to be designed and used for military application and/or purpose.

The delivery of this product to the countries and/or regions where the embargoes are imposed by U.N. is prohibited.

The application and delivery of this product must comply with Strategic High-Tech Commodities (SHTC) export control and the sales to the embargoed and/or sanctioned countries or regions are strictly prohibited.

6. DATE CODE OF PRODUCTS

Date code will be shown on each product :

Y MM DD - XXX
| | | |
Year Month Day - Production lots

Example: 2 1 2 2 3 - 0 0 3 ==>Year 2002, Dec.,23rd , Batch no.03

7. PACKING

Instruction of lot number:

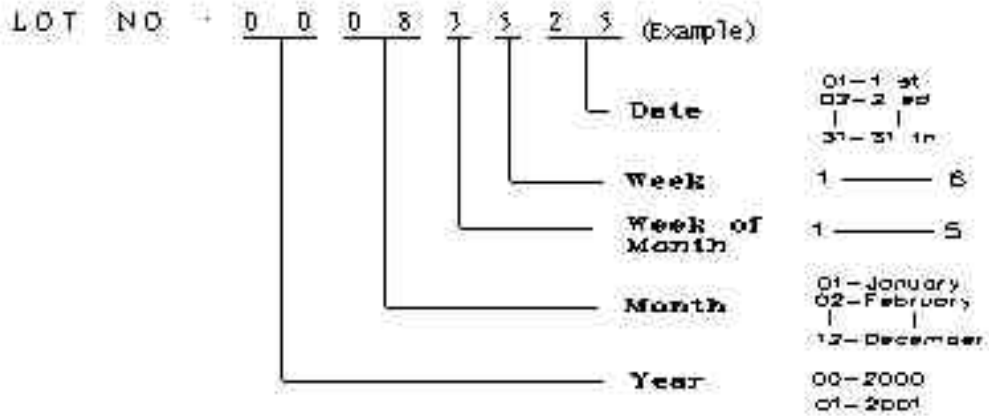

Label of carton:

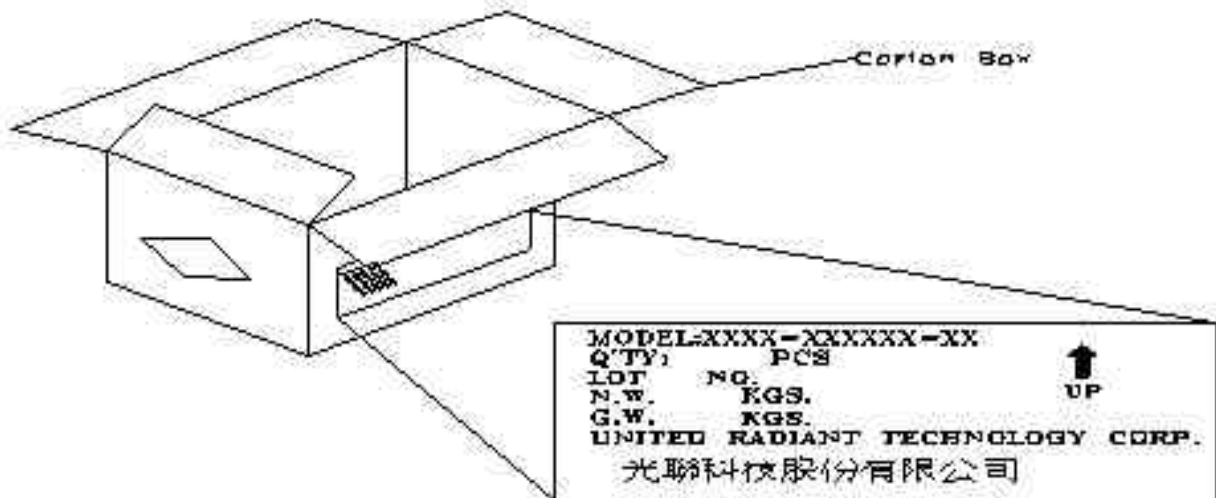

Packing tray must be stacked with alternated direction to each others.
 To tacks packing trays in same direction will cause product damaged.

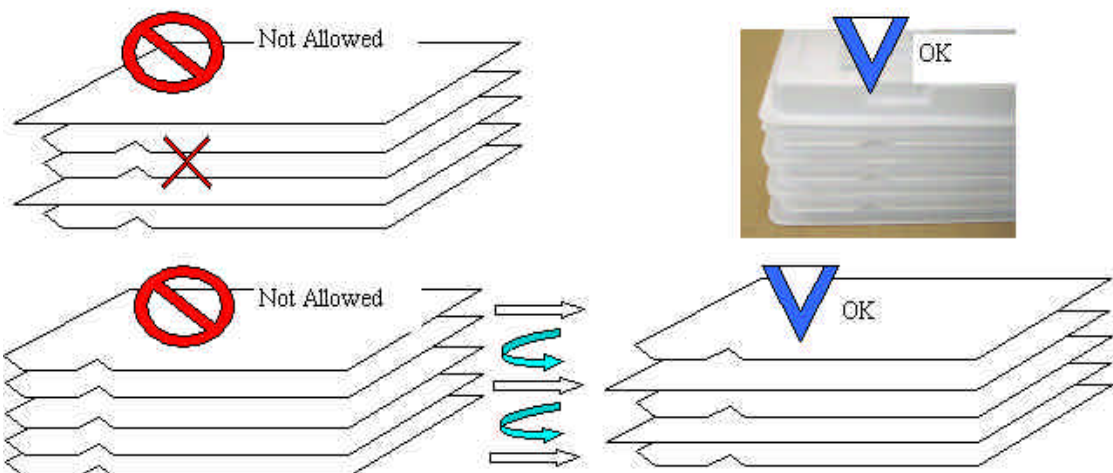

4 pcs / Tray
 5+1 Tray / Box
 4 Box / Carton
 80 pcs / Carton

NOTE:

(1) TRAY盤擺放請注意方向，
 務必180°交錯疊放，
 否則 LCD壓損請自行負責。

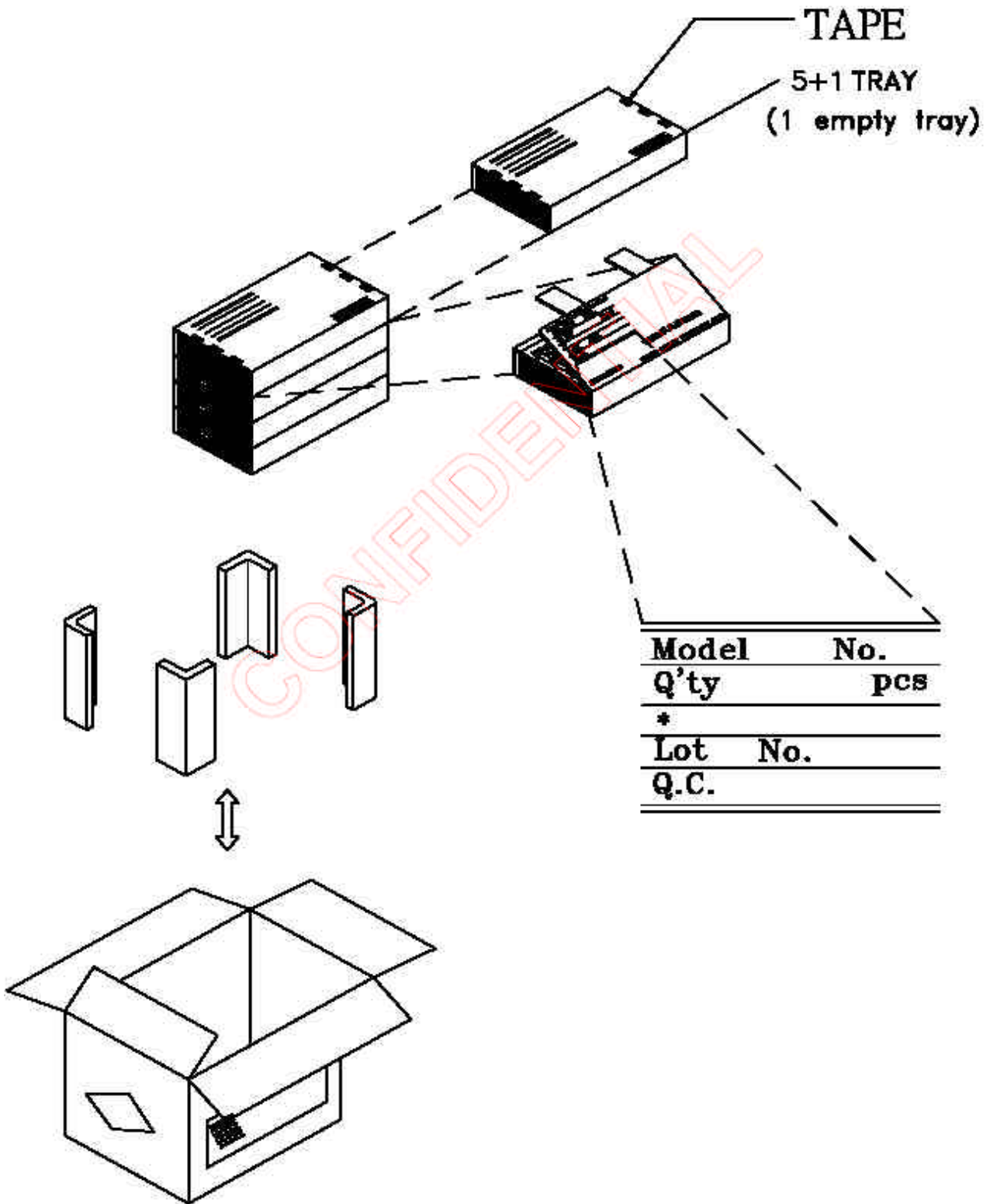

8. INSPECTION STANDARD

8.1. QUALITY :

THE QUALITY OF GOODS SUPPLIED TO PURCHASER SHALL COME UP TO THE FOLLOWING STANDARD.

8.1.1. THE METHOD OF PRESERVING GOODS

AFTER DELIVERY OF GOODS FROM U.R.T. TO PURCHASER. PURCHASER SHALL CONTROL THE LCM AT -10 40 ,AND IT MIGHT BE DESIRABLE TO KEEP AT THE NORMAL ROOM TEMPERATURE AND HUMIDITY UNTIL INCOMING INSPECTION OR THROWING INTO PROCESS LINE.

8.1.2. INCOMING INSPECTION

(A) THE METHOD OF INSPECTION

IF PURCHASER MAKE AN INCOMING INSPECTION , A SAMPLING PLAN SHALL BE APPLIED ON THE CONDITION THAT QUALITY OF ONE DELIVERY SHALL BE REGARDED AS ONE LOT.

(B) THE STANDARD OF QUALITY

ISO-2859-1 (or MIL-STD-105E) , LEVEL SINGLE PLAN.

CLASS	AQL(%)
CRITICAL	0.4 %
MAJOR	0.65 %
MINOR	2.5 %
TOTAL	2.5 %

EVERY ITEM SHALL BE INSPECTED ACCORDING TO THE CLASS.

(C) MEASURE

IF AS THE RESULT OF ABOVE RECEIVING INSPECTION , A LOT OUT IS DISCOVERED. PURCHASER SHALL BE INFORM SELLER OF IT WITHIN SEVEN DAYS. BUT FIRST SHIPMENT WITHIN FOURTEEN DAYS.

8.1.3. WARRANTY POLICY

U.R.T. WILL PROVIDE ONE-YEAR WARRANTY FOR THE PRODUCTS ONLY IF UNDER SPECIFICATION OPERATING CONDITIONS. U.R.T. WILL REPLACE NEW PRODUCTS FOR THESE DEFECT PRODUCTS WHICH UNDER WARRANTY PERIOD AND BELONG TO THE RESPONSIBILITY OF U.R.T.

8.2. CHECKING CONDITION

8.2.1. CHECKING DIRECTION SHALL BE IN THE 45 DEGREE AREA TO FACE THE SAMPLE.

8.2.2. CHECKER SHALL SEE OVER 30 cm. WITH BARE EYES FAR FROM SAMPLE AND USING 2 PCS. OF 20W FLUORESCENT LAMP.

8.3. INSPECTION PLAN :

CLASS	ITEM	JUDGEMENT	CLASS
PACKING & INDICATE	1. OUTSIDE AND INSIDE PACKAGE INDICATIONS	"MODEL NO." , "LOT NO." AND "QUANTITY" SHOULD INDICATE ON THE PACKAGE.	Minor
	2. MODEL MIXED AND QUANTITY	OTHER MODEL MIXED.....REJECTED QUANTITY SHORT OR OVER.....REJECTED	Critical
	3. PRODUCT INDICATION	"MODEL NO." SHOULD INDICATE ON THE PRODUCT	Major
ASSEMBLY	4. DIMENSION, LCD GLASS SCRATCH AND SCRIBE DEFECT.	ACCORDING TO SPECIFICATION OR DRAWING.	Major
APPEARANCE	5. VIEWING AREA	POLARIZER EDGE OR LCD'S SEALING LINE IS VISABLE IN THE VIEWING AREAREJECTED	Minor
	6. BLEMISH, BLACK SPOT, WHITE SPOT IN THE LCD AND LCD GLASS CRACKS	ACCORDING TO STANDARD OF VISUAL INSPECTION (INSIDE VIEWING AREA)	Minor
	7. BLEMISH, BLACK SPOT WHITE SPOT AND SCRATCH ON THE POLARIZER	ACCORDING TO STANDARD OF VISUAL INSPECTION (INSIDE VIEWING AREA)	Minor
	8. BUBBLE IN POLARIZER	ACCORDING TO STANDARD OF VISUAL INSPECTION (INSIDE VIEWING AREA)	Minor
	9. LCD'S RAINBOW COLOR	STRONG DEVIATION COLOR (OR NEWTON RING) OF LCD.....REJECTED. OR ACCORDING TO LIMITED SAMPLE (IF NEEDED, AND INSIDE VIEWING AREA)	Minor
ELECTRICAL	10. ELECTRICAL AND OPTICAL CHARACTERISTICS	ACCORDING TO SPECIFICATION OR DRAWING . (INSIDE VIEWING AREA)	Critical
	11.MISSING LINE	MISSING DOT, LINE, CHARACTERREJECTED	Critical
	12.SHORT CIRCUIT, WRONG PATTERN DISPLAY	NON DISPLAY, WRONG PATTERN DISPLAY, CURRENT CONSUMPTION OUT OF SPECIFICATION..... REJECTED	Critical
	13. PIN HOLE, PATTERN DEFORMITY	ACCORDING TO STANDARD OF VISUAL INSPECTION	Minor

8.4. STANDARD OF VISUAL INSPECTION

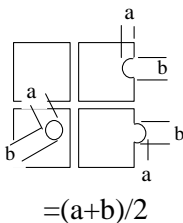
NO.	CLASS	ITEM	JUDGEMENT																																			
8.4.1	MINOR	<p>. BLEMISH, BLACK SPOT, WHITE SPOT IN THE LCD.</p> <p>. BLEMISH, BLACK SPOT, WHITE SPOT AND SCRATCH ON THE POLARIZER</p>	<p>(A) ROUND TYPE: unit : mm.</p> <table border="1"> <thead> <tr> <th colspan="2">DIAMETER (mm.)</th> <th>ACCEPTABLE Q'TY</th> </tr> </thead> <tbody> <tr> <td colspan="2">0.1</td> <td>DISREGARD</td> </tr> <tr> <td>0.1 <</td> <td>0.2</td> <td>5</td> </tr> <tr> <td>0.2 <</td> <td>0.3</td> <td>3</td> </tr> <tr> <td>0.3 <</td> <td></td> <td>0</td> </tr> </tbody> </table> <p>(B) LINER TYPE: unit : mm.</p> <table border="1"> <thead> <tr> <th>LENGTH</th> <th colspan="2">WIDTH</th> <th>ACCEPTABLE Q'TY</th> </tr> </thead> <tbody> <tr> <td>-----</td> <td>W</td> <td>0.03</td> <td>DISREGARD</td> </tr> <tr> <td>L 5.0</td> <td>0.03 <</td> <td>W 0.05</td> <td>5</td> </tr> <tr> <td>L 5.0</td> <td>0.05 <</td> <td>W 0.07</td> <td>2</td> </tr> <tr> <td>-----</td> <td>0.07 <</td> <td>W</td> <td>FOLLOW ROUND TYPE</td> </tr> </tbody> </table>	DIAMETER (mm.)		ACCEPTABLE Q'TY	0.1		DISREGARD	0.1 <	0.2	5	0.2 <	0.3	3	0.3 <		0	LENGTH	WIDTH		ACCEPTABLE Q'TY	-----	W	0.03	DISREGARD	L 5.0	0.03 <	W 0.05	5	L 5.0	0.05 <	W 0.07	2	-----	0.07 <	W	FOLLOW ROUND TYPE
DIAMETER (mm.)		ACCEPTABLE Q'TY																																				
0.1		DISREGARD																																				
0.1 <	0.2	5																																				
0.2 <	0.3	3																																				
0.3 <		0																																				
LENGTH	WIDTH		ACCEPTABLE Q'TY																																			
-----	W	0.03	DISREGARD																																			
L 5.0	0.03 <	W 0.05	5																																			
L 5.0	0.05 <	W 0.07	2																																			
-----	0.07 <	W	FOLLOW ROUND TYPE																																			
8.4.2	MINOR	BUBBLE IN POLARIZER	<p style="text-align: right;">unit : mm.</p> <table border="1"> <thead> <tr> <th>DIAMETER</th> <th>ACCEPTABLE Q'TY</th> </tr> </thead> <tbody> <tr> <td>0.3</td> <td>DISREGARD</td> </tr> <tr> <td>0.3 <</td> <td>3</td> </tr> <tr> <td>0.5 <</td> <td>1</td> </tr> <tr> <td>1.0 <</td> <td>0</td> </tr> </tbody> </table>	DIAMETER	ACCEPTABLE Q'TY	0.3	DISREGARD	0.3 <	3	0.5 <	1	1.0 <	0																									
DIAMETER	ACCEPTABLE Q'TY																																					
0.3	DISREGARD																																					
0.3 <	3																																					
0.5 <	1																																					
1.0 <	0																																					
8.4.3	MINOR	PIN HOLE , PATTERN DEFORMITY	<p style="text-align: right;">unit : mm.</p> <div style="display: flex; align-items: center;">  <table border="1" style="margin-left: 20px;"> <thead> <tr> <th>DIAMETER</th> <th>ACC. Q'TY</th> </tr> </thead> <tbody> <tr> <td>0.1</td> <td>DISREGARD</td> </tr> <tr> <td>0.1 <</td> <td>3</td> </tr> <tr> <td>0.25 <</td> <td>0</td> </tr> </tbody> </table> </div>	DIAMETER	ACC. Q'TY	0.1	DISREGARD	0.1 <	3	0.25 <	0																											
DIAMETER	ACC. Q'TY																																					
0.1	DISREGARD																																					
0.1 <	3																																					
0.25 <	0																																					

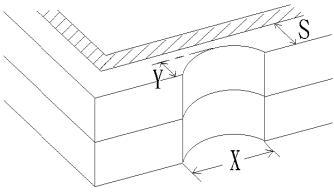
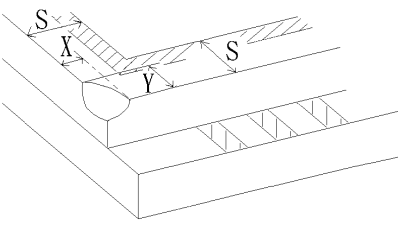
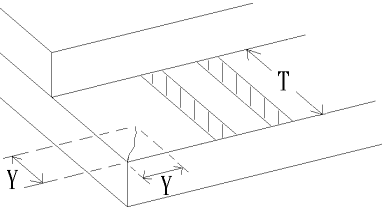
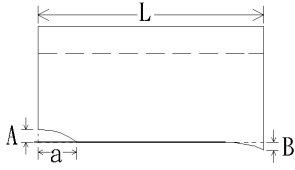
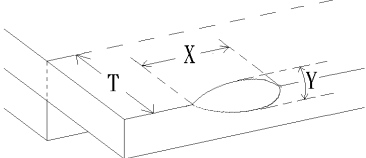
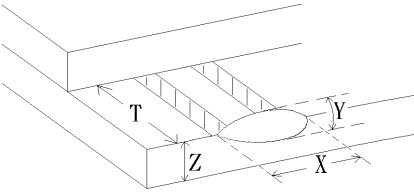
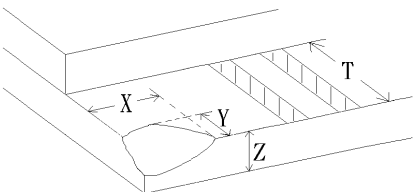
NO.	CLASS	ITEM	JUDGEMENT
8.4.4	MINOR	CHIPPING	 $Y > S$ REJ.
8.4.5	MINOR	CHIPPING	 or $Y > S$ REJ.
8.4.6	MAJOR	GLASS CRACK	 $Y > (1/2) T$ REJ.
8.4.7	MAJOR	SCRIBE DEFECT	 $a > L/3, A > 1.5\text{mm.}$ REJ. B : ACCORDING TO DIMENSION
8.4.8	MINOR	CHIPPING (ON THE TERMINAL AREA)	 $= (x+y)/2 > 2.5 \text{ mm}$ REJ.
8.4.9	MINOR	CHIPPING (ON THE TERMINAL SURFACE)	 $Y > (1/3) T$ REJ.
8.4.10	MINOR	CHIPPING	 $Y > T$ REJ.